

Pi 2 Design

MERCURY V3

Hardware Reference Manual

© 2024 PI 2 Design

DRAFT

Table of Contents

1 Warranty..... 3

2 Operating Specifications..... 4

 2.1 MERCURY V3 Operating specifications 4

3 Overview 5

 3.1 Introduction 5

 3.2 Block Diagram..... 5

4 On-Board Devices 7

 4.1 Overview 7

 4.2 Raspberry Pi 4 7

 4.2 WM8804 SPDIF Transmitter 7

 4.2.1 WM8804 SPDIF Transmitter Notes 8

 4.3 Dual High Resolution NDK Clocks..... 8

 4.4 High Speed Differential Transmitter..... 8

 4.5 I2S Parallel Buffer..... 8

 4.6 I2S Differential Driver..... 8

5 PI4 Ports and GPIO 9

 5.1 Overview..... 9

 5.2 Compute Module 4 GPIO 9

 5.2.1 PI4 GPIO Notes 10

6 MERCURY V3 Power 11

 6.1 Overview..... 11

7 MERCURY V3 Software 13

8 Connector Locations 14

 8.1 Overview..... 14

 8.2 Front and Rear Panel and Interior Views..... 14

 8.3 Pi 4 - Dual USB 2.0 and Dual USB3.0..... 14

 8.4 Pi 4 - Gigabit Ethernet..... 15

 8.5 Pi 4 - HDMI 0 15

 5.15 Pi 4 - Micro-SD Card 15

 5.16 I2S Over HDMI..... 15

 9.1 DC Input Jack 16

 5.17 TOSLINK OPTO 16

 5.18 RCA SPDIF..... 16

 9.2 XLR AES Balanced..... 16

 9.3 BNC AES Single Ended..... 16

 9.4 Parallel I2s over RJ45..... 16

10 Document Revisions..... 18

11 Errata..... 19

 11.15 Overview 19

List of Figures

Figure 1 – MERCURY V3 Block Diagram 6

Figure 2 – MERCURY V3 Power, Simplified Block Diagram 11

Figure 3 – MERCURY V3 Power Control Schematic..... 12

Figure 4 – MERCURY V3 Front Panel..... 14

Figure 5 – MERCURY V3 Rear Panel..... 14

1 WARRANTY

The enclosed product ("the Product") is warranted by Pi 2 Design for a period of one year for reasonable, individual home use, all as further described and defined below. This warranty runs solely to the individual purchasing the Product and is not transferable or assignable in any respect. This warranty is valid only for so long as the product is used intact as shipped from Pi 2 Design. Any attempt or effort to alter the Product, including but not limited to any attempt to solder, de-solder, unplug, replace, add or affix any part or component of or onto the Product, other than components specifically intended for the user to plug and unplug into appropriate sockets and/or Connectors to facilitate intended use and deployment, all as specifically described and authorized in this Product Hardware Reference Manual, shall void this warranty in all respects. Coverage under this warranty requires that the Product be used and stored at all times in conditions with proper electrostatic protection necessary and appropriate for a complex electronic device. These conditions include proper temperature, humidity, radiation, atmosphere and voltage (standard commercial environment, 0C to +70C, <60%RH). Any Product that has been modified without the express, prior written consent of Pi 2 Design is not covered by this warranty. The use or connection of any adapter or component with any device other than a Pi 2 Design Connector or adapter shall void this warranty and the warranty of all other components, parts and modules connected to the rest of the system. Pi 2 Design shall not be responsible for any damage to the Product as a result of a customer's use or application of circuitry not developed or approved by Pi 2 Design for use on or in connection with the Product.

This warranty does not cover defects caused by electrical or temperature fluctuations or from stress resulting from or caused by abuse, misuse or misapplication of the Product. Any evidence of tampering with the serial number on the Product shall immediately void this warranty. Notwithstanding anything to the contrary herein, Pi 2 Design expressly disclaims any implied warranty of merchantability or implied warranty of fitness for a particular purpose in connection with the manufacture or use of the Product.

2 OPERATING SPECIFICATIONS

2.1 MERCURY V3 OPERATING SPECIFICATIONS

MERCURY V3 conforms to the following specifications:

Specification	Value
Dimensions	170mm x 123.2mm x 53.5mm (6.7" x 4.85" x 2.1")
Weight	~1.2kg (3 lbs.)
Storage Temperature	-20C to +85C (-4F to 185F)
Operating Temperature	0C to +70C (32F to 158F)
Humidity	0% to 95% RH, Non-Condensing
Input Voltage (VIN)	+12V +/- 20% DC
Power Consumption	5W Typical, 12W Maximum (not including USB peripherals)

Table 1 – MERCURY V3 Operating Specifications

3 OVERVIEW

3.1 INTRODUCTION

MERCURY V3, designed and manufactured by PI 2 Design, is a Raspberry Pi 4 based device designed for Professional, Studio Grade, AES and I2S Digital Audio Streaming. MERCURY V3 converts the Raspberry Pi 4 I2S Interface to High-Definition Digital Audio Coax, OPTO and Balanced XLR. These multiple, simultaneously active digital audio outputs allow MERCURY V3 to optimally interface with virtually any High-Performance DAC on the market.

The major features of MERCURY V3 are as follows:

- **RASPBERRY PI 4** - This Single Board Computer provides 4 High Performance ARM Cores, 4K HDMI Output, USB2 x 2, USB3 x 2, Gigabit Ethernet, 4/8GB DRAM and more.
- **GIGABIT ETHERNET** - A standard RJ45 Provides the interface to the Pi4 Gigabit Ethernet I/F.
- **DUAL EXTERNAL USB3** - These connectors provide two 5Gbit USB3 Host Ports.
- **DUAL EXTERNAL USB2** - These connectors provide two USB2 Host Ports.
- **EXTERNAL HDMI** – A 4K HDMI Connector allows access to the Pi4 HDMI Output 0.
- **AES TRANSMITTER** – The industry standard WM8804 converts the Pi4 I2S stream to AES3/SPDIF formatted data at 24-Bit up to the maximum AES Standard data rate of 192Khz.
- **AES COAX OUTPUT** – A 1:1 Isolation Transformer provides Bit Perfect Impedance Controlled Digital Audio Data @ 1V AES Standard Level.
- **AES BALANCED OUTPUT** – A high speed differential transmitter with a 1:1 Isolation Transformer provides balanced audio data via the Professional XLR Connector.
- **TOSLINK OPTICAL OUTPUT** – Isolated Optical Transmitter Drives Consumer Level DAC's.
- **SPDIF COAX OUPUT** - A 1:1 Isolation Transformer provides Bit Perfect Impedance Controlled Digital Audio Data @ 0.6V Consumer Standard Level.
- **DIFFERENTIAL I2S OUTPUT** – An LVDS Differential Transmitter drives the I2S Bus over an HDMI Connector. PS-Audio and Audio-GD pinouts are supported
- **PARALLEL I2S OUTPUT** – An RJ45 carries a buffered version of the I2S Bus for short distance use.
- **HIGH RESOLUTION CLOCKS** – A pair of Ultra-Low Noise NDK NZ2520SDA oscillators drive the WM8804 AES transmitter in non-PLL mode for the lowest possible noise.
- **ULTRA-LOW NOISE LDO's** – Two Ultra-Low Noise, High-PSRR LDO's supply power to the WM8804 AES transmitter and the NDK Clock's.
- **LINEAR PRE_REGULATOR** - LT2941 LDO 5V pre-regulator allows the critical clock and AES transmitter sections to be linear when an external linear PSU is used.
- **LOW NOISE PCB LAYOUT** – 4-layer Split Ground PCB with noise reduction techniques refined from years of High-Speed Mixed-Signal Design work.
- **EXTRUDED ALUMINUM ENCLOSURE** – Rugged, Aircraft Grade Aluminum, Anodized for Scratch Resistance
- **PRE-PROGRAMMED 32GB SD CARD** - Mercury comes with a 32GB SD Card loaded with Volumio 3.x (other OS's TBD)

3.2 BLOCK DIAGRAM

Refer to the following figure for a block diagram of MERCURY V3.

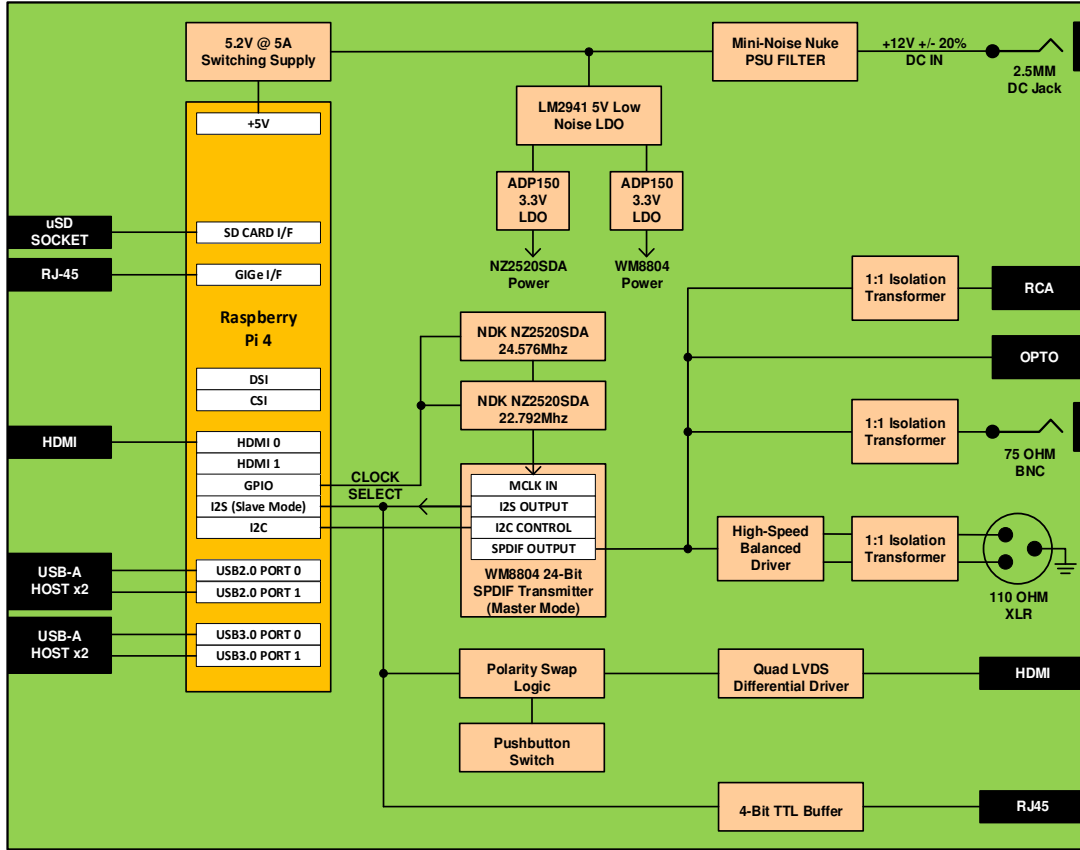

Figure 1 – MERCURY V3 Block Diagram

PRELIMINARY

4 ON-BOARD DEVICES

4.1 OVERVIEW

This section describes in detail the devices located on the Mercury Streamer.

4.2 RASPBERRY PI 4

MERCURY V3 uses the latest Raspberry Pi 4 Model B. This powerful Single Board Computer (SBC) runs the software required to perform the Digital Audio Player function as well as other applications. MERCURY V3 interfaces to the PI4 via a 40-Pin GPIO connector. Key features of the PI4 (as used on the Mercury Streamer) are as follows:

- Broadcom BCM2711, Quad core Cortex-A72 (ARM v8) 64-bit SoC @ 1.8GHz
- H.265 (HEVC) (4Kp60 decode), H.264 (1080p60 decode, 1080p30 encode)
- OpenGL ES 3.1 and Vulkan 1.0 3D graphics support
- 4GB LPDDR4-3200 SDRAM
- 2.4 GHz, 5.0 GHz IEEE 802.11 b/g/n/ac wireless
- Bluetooth 5.0, BLE
- Gigabit Ethernet PHY supporting IEEE 1588
- Dual USB3.0 Ports
- Dual USB 2.0 Ports
- I2C and I2S Peripheral Ports
- HDMI 2.0 Port (up to 4Kp60 supported)
- SDIO 2.0

4.2 WM8804 SPDIF TRANSMITTER

At the core of MERCURY V3 is the Cirrus Logic WM8804 AES Digital Audio Transmitter. This device interfaces to the Compute Module 4 via I2S and I2C. The signals used to interface with the WM8804 are shown in the following table.

WM8804 Signal	PI4 Signal	Description
MCLK	-	Unused
BCLK	BCLK	I2S Bit Clock Output to Pi
LRCLK	LRCLK	I2S Word Clock Output to Pi
SDIN	SDOUT	I2S Serial Audio Data Input from Pi
SCL	SCL	I2C Clock from Pi
SDA	SDA	I2C Data to/from Pi

XIN	GPIO6	0 = Select 22.5792Mhz Input Clock for 44.1Khz, 88.2Khz and 176.4Khz Frame Rates 1 = Select 24.576Mhz Input Clock for 48Khz, 92Khz and 192Khz Frame Rates
TXO	-	AES3/SPDIF encoded digital audio output

Table 2 – PI4 to WM8804 Connections

4.2.1 WM8804 SPDIF TRANSMITTER NOTES

1. The WM8804 is controlled using the I2C port. Refer to the WM8804 documentation and installed player software.
2. MERCURY V3 is designed to operate the WM8804 in Master mode. In this mode the WM8804 receives its master clock from XIN and drives MCLK (unused by the PI4), BCLK and LRCLK out. Serial Data in is received from PI4.

4.3 DUAL HIGH RESOLUTION NDK CLOCKS

A pair of NDK NZ2520SDA Ultra-Low Noise clocks provide the critical timing signals for the WM8804. They are selected via Compute Module 4 GPIO6 (0 = 22.5792Mhz and 1 = 24.576Mhz).

4.4 HIGH SPEED DIFFERENTIAL TRANSMITTER

A High-Speed (50Mbps) Differential Transmitter accepts the SPDIF output from the WM8804 and sends it as a balanced pair to the 1:1 Isolation Transformer and then on to the XLR connector.

4.5 I2S PARALLEL BUFFER

A 4-Bit TTL Logic Buffer is used to drive the I2S signals (MCLK, BCKL, LRCLK and SDO) to the RJ45. This device is designed to drive the I2S Bus up to 1 meter (3 feet).

4.6 I2S DIFFERENTIAL DRIVER

A Quad Differential LVDS Driver takes the I2S Bus and converts each signal into a balanced differential signal. This is then connected to an HDMI connector. This device is designed to drive the I2S Bus up to 3 meters (10 feet).

5 PI4 PORTS AND GPIO

5.1 OVERVIEW

MERCURY V3 uses several of the internal functions and GPIO from the PI4 for control and status purposes.

5.2 COMPUTE MODULE 4 GPIO

The PI4 provides a large number of General Purpose I/O (GPIO) pins. These pins also can be assigned to alternate functions as defined in the PI4 documentation. The usage of these pins (and alternate functions) on MERCURY V3 are described in the following table.

GPIO	DIR	AF	PUP PDN	Mercury Streamer Usage	Description/Notes
0	I/O	I2C0	PUP	unused	Routed to P5 for DSI 0
1	I/O	I2C0	PUP	unused	Routed to P5 for DSI 0
2	I/O	I2C1	PUP	SDA	I2C Data for MERCURY V3and Expansion
3	I/O	I2C1	PUP	SCL	I2C Clock for MERCURY V3and Expansion
4	-			unused	
5	I/O			GPIO5	WM8804 Master Clock 22.5792Mhz
6	I/O			GPIO6	WM8804 Master Clock 24.5760Mhz
7	-			unused	
8	-			unused	
9	-			unused	
10	-			unused	
11	-			unused	
12	-			unused	
13	-			unused	
14	OUT			*PLED	Front Panel Power LED, Low True
15	-			unused	

GPIO	DIR	AF	PUP PDN	Mercury Streamer Usage	Description/Notes
16	-			unused	
17	OUT			*ALED	Front Panel Activity LED, Low True
18	IN	I2S		BCLK	I2S Bit Clock from WM8804
19	IN	I2S		WCLK	I2S Word Clock from WM8804
20	-			unused	
21	OUT	I2S		SDOUT	I2S Serial Data to WM8804
22	-			unused	
23	IN			*PSW	Front Panel Power Switch, Low True
24	-			unused	
25	-			unused	
26	-			unused	
27	OUT		PUP	PHLD	Power Hold to Power Circuit

Table 3 – PI4 Port and GPIO Pin Assignments

5.2.1 PI4 GPIO NOTES

1. DIR is from the point of view of the PI4.
2. Alternate Function (AF) column indicates that the use of this pin requires the pin to be assigned to the named function as defined by the PI4 specifications.
3. PUP/PDN indicates if the GPIO should have its associated Pullup (PUP) or Pulldown (PDN) resistor enabled.
4. An asterisk “*” at the beginning of the name indicates a low true signal.

6 MERCURY V3POWER

6.1 OVERVIEW

MERCURY V3 is designed to be powered from an external +12V source.

See the block diagram below for a simplified view of MERCURY V3 power flow.

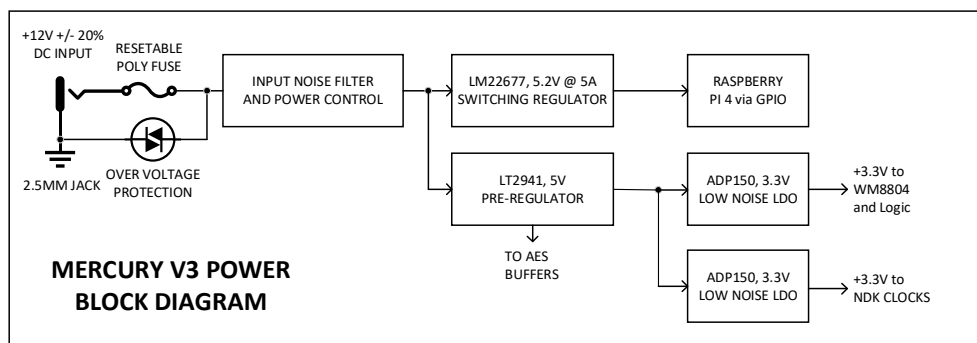

Figure 2 – MERCURY V3Power, Simplified Block Diagram

6.2 POWER CONTROL

This circuit allows software to monitor and control the power state of the Mercury Streamer. It uses two GPIO to perform the Power Hold and Power State functions. This circuit is compatible with the Volumio 503HTA Plug-In. Note that by default the circuit simply follows the state of the Pushbutton Power Switch.

This circuit is shown in the figure below.

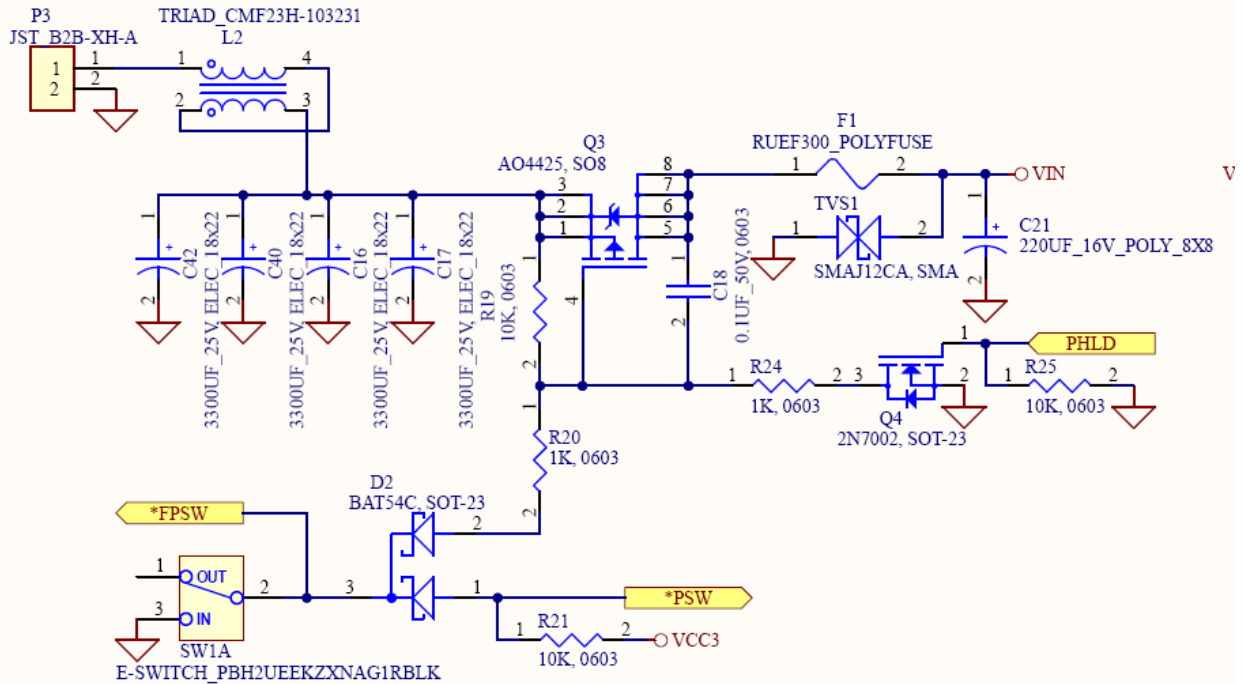

Figure 3 – MERCURY V3 Power Control Schematic

6.3 POWER STATUS

As part of the power control circuit, GPIO23 (*PSW) is used to sense the state of the Pushbutton Power Switch. A low indicates that the Power Switch is in the on position (depressed). When high it indicates that the user has placed the switch into the off position (non-depressed) thus opening the on/off switch. Note that for proper operation this circuit requires user software to program GPIO23 as an input.

6.4 POWER HOLD

GPIO27 (PHLD) allows the PI4 to hold the power on even after the user puts the Power Switch into the off position. After initialization, software can drive GPIO27 high, thus holding the power on regardless of the state of the on/off switch. Driving this low, removes this hold condition. Note that for proper operation this requires user software to program GPIO27 as an output with the internal pullup disabled.

7 MERCURY V3 SOFTWARE

7.1 OVERVIEW

Due to the various resources interfaced on the Mercury Streamer, both internal and external to the PI4, it is necessary to initialize a large number of CPU registers and external devices before correct operation can begin. These values and their proper sequencing are beyond the scope of this document.

7.2 COMPATIBLE DRIVER

Most Audio Player software will support Mercury V3 using either the “Pi2design PI2AES” or “HifiBerry Digi+ Pro” driver.

7.3 USER_CONFIG.TXT

The following statements need to be added to the Linux “user_config.txt” file. These allow proper operation of the front panel power switch and LED’s as well as the power hold function.

```
# Hold power on after we boot
```

```
gpio=27=op,dh
```

```
#Trigger power off when switch is in off position:
```

```
dtoverlay=gpio-shutdown,gpio_pin=23,active_low=0,gpio_pull=up,debounce=5000
```

```
# Assign Power LED Function to GPIO 17 and make it low true
```

```
dtparam=pwr_led_gpio,gpio_pin=17
```

```
dtparam=pwr_led_activelow
```

8 CONNECTOR LOCATIONS

8.1 OVERVIEW

This section provides the type, location, and pinout for the various connectors on the Mercury Streamer.

8.2 FRONT AND REAR PANEL AND INTERIOR VIEWS

This shows the front and rear panels of MERCURY V3.

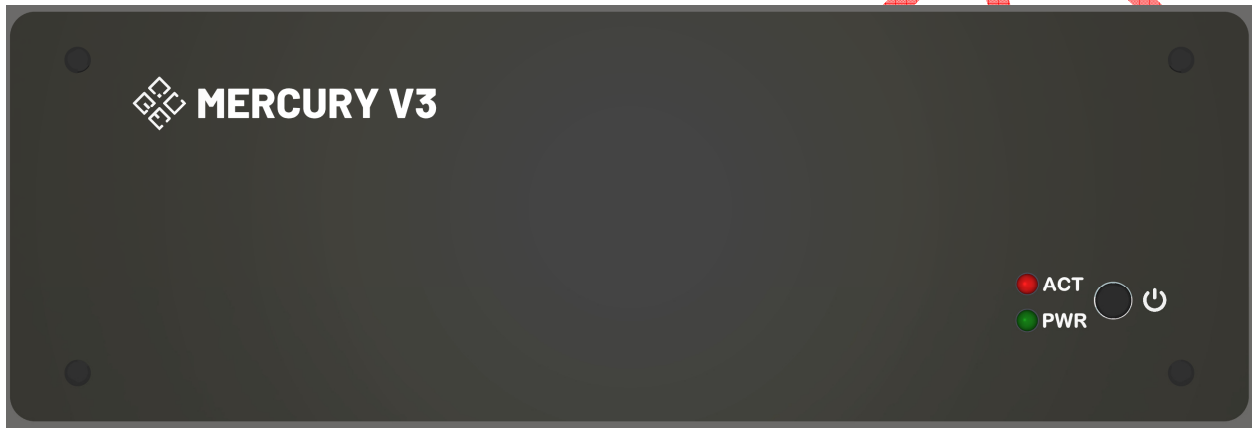

Figure 4 – MERCURY V3 Front Panel



Figure 5 – MERCURY V3 Rear Panel

8.3 PI 4 - DUAL USB 2.0 AND DUAL USB3.0

These standard Dual USB2.0 (grey) and USB3.0 (blue) Host connectors conform to the industry standard USB2.0 pinout. They can be used for mass storage, wireless peripherals, etc. They provide up to 1.2A @ 5V each.

8.4 PI 4 - GIGABIT ETHERNET

This is a standard CAT5 RJ45 and conforms to the industry Pinout. It is connected to the PI4 Ethernet Port.

8.5 PI 4 - HDMI 0

9 This is a standard HDMI female connector connected to PI4 HDMI Port 0 via an HDMI Panel Cable.

5.15 PI 4 - MICRO-SD CARD

This is a standard Micro-SD Socket and conforms to the industry standard Pinout. It is connected to the PI4 SDIO Port via an SD Card Extender.

5.16 I2S OVER HDMI

This is a standard HDMI Female connector that carries the Differential I2S signal. Pinout conforms to the PS Audio standards. The Pinout for this connector is shown in the following table.

P15 PIN	Name	Description
1	SDO+ SDO-	I2S Data Plus (Polarity Switch Out) I2S Data Minus (Polarity Switch In)
2	GND	Ground
3	SDO- SDO+	I2S Data Minus (Polarity Switch Out) I2S Data Plus (Polarity Switch In)
4	BCK+	I2S Bit Clock Plus
5	GND	Ground
6	BCK-	I2S Bit Clock Minus
7	WCK+ WCK-	I2S Word Clock Plus (Polarity Switch Out) I2S Word Clock Minus (Polarity Switch In)
8	GND	Ground
9	WCK- WCK+	I2S Word Clock Minus (Polarity Switch Out) I2S Word Clock Plus (Polarity Switch In)
10	MCK+	I2S Master Clock Plus
11	GND	Ground
12	MCK-	I2S Master Clock Minus
13	NC	No Connect

P15 PIN	Name	Description
14	NC	No Connect
15	P15	Pulled to GND with 10K ohm resistor
16	P16	Pulled to GND with 10K ohm resistor
17	GND	Ground
18	+5V	Connected to +5V via 100 ohm resistor
19	NC	No Connect

Table 4 – I2S Over HDMI Pinout

9.1 DC INPUT JACK

This is a 2.5MM Center Positive DC Jack.

5.17 TOSLINK OPTO

This carries the Optical TOSLINK digital audio output

5.18 RCA SPDIF

This RCA connector carries the SPDIF digital audio output

9.2 XLR AES BALANCED

This 3-pin connector carries the Balanced AES Digital Audio output.

9.3 BNC AES SINGLE ENDED

This right-angle BNC 75-ohm female connector carries the Single Ended AES Digital Audio output.

9.4 PARALLEL I2S OVER RJ45

This 8-pin RJ45 carries a buffered version of the I2S Bus for short distance ($\leq 1M$) use. The Pinout for this connector is shown in the following table.

P15 PIN	Name	Description
1	SDO	I2S Data
2	GND	Ground
3	WCK	I2S Word (Left/Right) Clock
4	GND	Ground
5	BCK	I2S Bit Clock

P15 PIN	Name	Description
6	GND	Ground
7	MCK	I2S Master Clock
8	GND	Ground

Table 5 – Parallel I2S Over RJ45 Pinout

PRELIMINARY

10 DOCUMENT REVISIONS

Date	Revision	Change
02/25/2024	P0.1	Preliminary Release

Table 6 – Document Revisions

PRELIMINARY

11 ERRATA

11.15 OVERVIEW

There are currently no errata for Mercury V3.

PRELIMINARY